

jΩ Electronics

MTP-7 MIDI-to-Parallel Converter

Installation and Operating Instructions

Product Description

The MTP-7 from j-Omega Electronics is an electronic circuit module which can switch up to 32 electrical loads on or off under the control of signals received from a data source complying with the Musical Instrument Digital Interface (MIDI) standard. MIDI 'note on' and 'note off' messages are used to control the MTP-7's outputs. The relationship between MIDI note and channel numbers and output numbers is determined by an internally stored configuration map which can be re-programmed as required by the user. In addition to its switching outputs, the MTP-7 also has a single expression output which produces an analogue voltage level proportional to the velocity value associated with the most recently enacted 'note on' message.

Installation

Carefully remove the MTP-7 circuit from its protective packaging, handling the board by its edges only. Five mounting holes of 3.2 mm diameter are provided on the circuit board to allow it to be fixed inside the instrument that it controls. Suitable methods of fixing include self-adhesive pillars and screws or bolts with insulating spacers. Whatever method is used, ensure that no metal can come into contact with any wiring tracks or components on the circuit board.

Connection

The MIDI input to the MTP-7 is via the standard 5-pin DIN connector at the end of the board, nearest the indicator LED. Signals received at this connector are passed to the adjacent MIDI Through connector allowing other MIDI equipment to be used simultaneously if required. All other connections are made using the 36-way screw terminal blocks as shown below. Use a screwdriver to tighten the screw terminals as connections are made. Support the circuit board to prevent it bending whilst tightening the screws, or the copper tracks may be damaged.

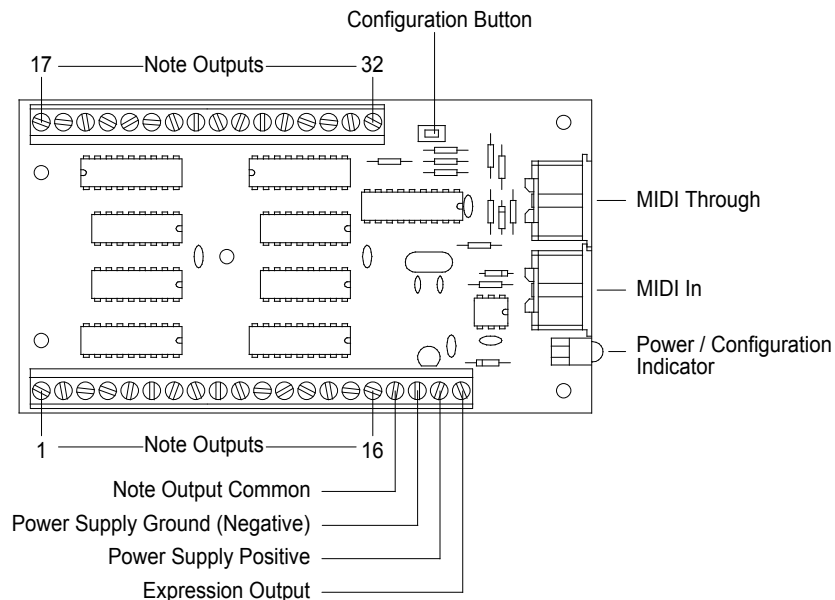

There is one screw terminal connection for each note output. One lead of each output device is connected to the appropriate output terminal of the MTP-7. The other leads of all the output devices must be connected together and this common point connected to the 'Note Output Common' terminal. If the polarity of the output devices is important, connect the positive lead of the output device to the common terminal.

DC Power Supply

The MTP-7 requires a DC supply in the range 8 to 35 Volts between the 'Power Supply Positive' and 'Power Supply Ground' terminals to power its on-board circuitry. This supply which must be adequately smoothed to maintain a minimum voltage of 8V at all times. The supply which powers the output loads does not, however, need to be smoothed unless this is required by the loads. The load power supply is connected between the 'Note Output Common' and 'Power Supply Ground' terminals, ensuring that positive voltage is applied to the 'Note Output Common' terminal. Three examples of possible power supply connection schemes are illustrated below :

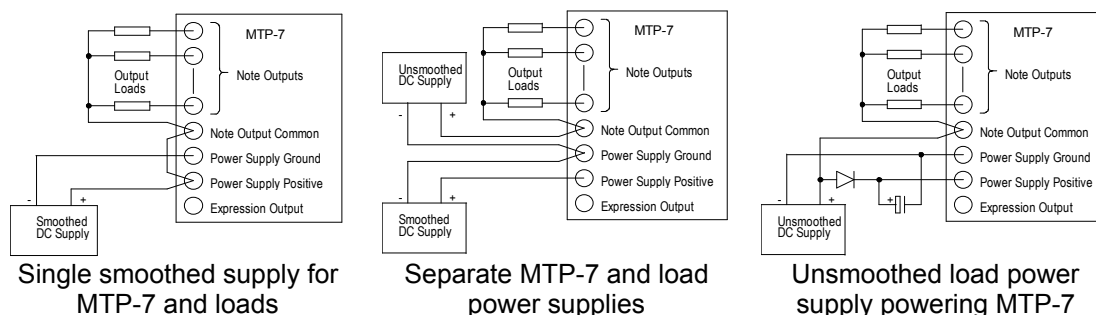

A simple unsmoothed DC power supply can be constructed from a low-voltage mains transformer and full-wave bridge rectifier. If a diode and capacitor is used to provide smoothed power to the MTP-7 as in the example above, the capacitor must be sized such that the ripple voltage does not cause the supply to drop below 8 V.

Operation

The MTP-7 is designed to be fitted as a permanent installation in a piece of equipment. Once installed, simply connecting the power to the unit will start its operation. Under normal operation, the LED near the MIDI input will be illuminated continuously whilst the power is on. Note outputs will be activated under control of the MIDI transmitter connected to the MTP-7, according to the internal configuration map.

As 'note on' events are received and outputs are switched on, the voltage on the expression output relative to the 'Power Supply Ground' terminal will be set to a level over the range 0 to 3.125 V, proportional to the velocity of the event just received. This output could be used to drive external sample-and-hold circuits, triggered by outputs switching on to give note-by-note expression control. Alternatively, it could be lowpass filtered to give an average expression level which could then drive the output common voltage via a power amplifier, giving velocity-controlled dynamic effects. If use of the expression output is not required, it can be left unconnected. The expression output has a high source resistance and it must be buffered by a high input-resistance amplifier if used to drive external circuitry.

Setting the Configuration Map

For each of its 32 outputs, the MTP-7 keeps a record of the MIDI channel number and MIDI note number that have together been assigned to control that output. MTP-7s are factory programmed with a configuration map corresponding to a rising chromatic scale on channel 1, starting at note number 36. If a different map is required, the unit must be placed into its configuration mode by holding down the Configuration whilst the board power is being switched on. Once in configuration mode, the indicator LED will flash rapidly and output number 1 will be switched on. Upon receipt of a MIDI 'note on' event, the MTP-7 will assign the note and channel numbers just received to output 1 in the configuration map, turn off output 1 and turn on output 2. The channel and note numbers of the next 'note on' event received will be assigned to output 2, etc. This process will continue until 32 'note on' events have been received, at which point the MTP-7 will end its configuration mode and commence normal operation. If the same note and channel are allocated to more than one output, only the lowest numbered output will be mapped and the other outputs will be inactive.

A time interval of at least 20 milliseconds must be allowed between 'note on' events, which corresponds to a maximum tempo of 3000 bpm when using crotchet-length notes. The expression output voltage will be set to zero whilst the MTP-7 is in its configuration mode.

Electrical and MIDI Specifications

Supply voltage: 8 to 35 V DC.

Supply current: 15 mA typical in addition to current drawn by output loads.

Power-up: Initial supply voltage rise rate must be greater than 0.05 V/ms for reliable starting.

Note outputs: Maximum current per output is 0.5 A continuous. Maximum total current for each group of 8 outputs (1-8, 9-16, 17-24, 24-32) is 2 A continuous at 25 °C.

Expression output: 0 to 3.125V in 16 equal voltage steps proportional to note 'on' velocity.

MIDI: Responds to Note On, Note Off, All Sounds Off, All Notes Off, Reset and Active Sensing.
Supports running status.
Recognises j-Omega encrypted MIDI protocol and automatically switches between encrypted and non-encrypted modes.

Important Note

Since the MTP-7 is intended to form part of an instrument system, these instructions are to be considered as being for guidance only. It is assumed that the installer has a level of competence appropriate to the system being constructed. j-Omega Electronics will take no responsibility for any accident or damage to personnel or property caused by the mis-use of any of its products.

It is the responsibility of the installer to ensure that any system incorporating this unit conforms to the relevant laws concerning electromagnetic compatibility (EMC) and/or electrical safety.

MIDI Implementation Chart

Function...		Transmitted	Recognised	Remarks
Basic Channel	Default	X	1-16	Set according to configuration map
	Changed	X	X	
Mode	Default	X	Mode 3	*1
	Messages	X	X	
	Altered	X	X	
Note Number:		X	0-127	Set according to configuration map
	True voice	X	*	
Velocity	Note ON	X	O v=1-127	Expression output resolution = 4 bits
	Note OFF	X	X	
After Touch	Keys	X	X	
	Ch's	X	X	
Pitch Bender		X	X	
Control Change		X	X	
Prog Change:		X	X	
	True #	X	X	
System Exclusive		X	X	
System Common:	Song Pos	X	X	
	Song Sel	X	X	
	Tune	X	X	
System Real Time:	Clock Commands	X	X	
		X	X	
Aux Messages:	Local ON/OFF	X	X	
	All Notes OFF	X	O (120)	
	All Sounds OFF	X	O (123)	
	Active Sense	X	O	
	Reset	X	O	
Notes		*1: Priority given to most recently received note on/off message on any particular note output.		

Mode 1: OMNI ON, POLY
Mode 3: OMNI OFF, POLY

Mode 2: OMNI ON, MONO
Mode 4: OMNI OFF, MONO

O : Yes
X : No

For the latest product information and support, please visit:

www.j-omega.co.uk