

j-Omega Electronics

IR-PAIR Installation and Use

Introduction

The IR-PAIR consists of an infra-red emitter diode and a sensitive, matched infra-red detector. Together, a device pair can optically detect the presence of a hole in punched roll/book music or the position of a keyboard key. The detector of the IR-PAIR is directly compatible with the PTM-1 Parallel-to-MIDI converter from j-Omega Electronics.

IR Detector

The IR detector (Osram SFH5140F) is side-looking and has a raised lens over the area that is sensitive to infra-red light and this must point towards its corresponding emitter. Mounting of the detector should be with its rear (flat) face on a flat surface.

It is recommended that a printed circuit board (PCB) be used to make the connection between the detector's leads and the wiring to the PTM-1 inputs, as the lead spacing is small and it may be difficult to solder wiring directly to the detector without adjacent connections shorting together. Using a PCB, detectors may be mounted either perpendicular or parallel to the board, as shown in the diagrams below:

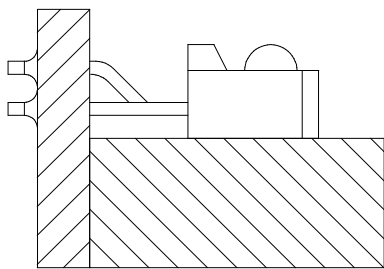

Perpendicular PCB Mount

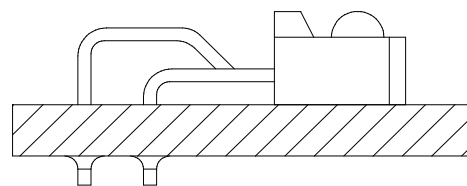

Parallel PCB Mount

In addition to the mechanical restraint offered by the PCB mounting, it is recommended that the detector be attached to the surface at the rear by gluing with epoxy or solvent-based clear adhesive.

The connections for the detector devices are as shown, as seen facing the lens:

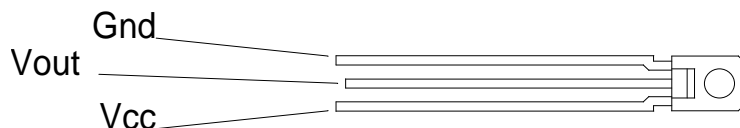

When used in conjunction with a PTM-1, detectors must be operated from a regulated 5 V power supply. When infra-red is detected, the output is driven actively low to Gnd. In dark conditions (no infra-red detected), an internal 10 k Ω pull-up resistor will allow the output to rise to Vcc. The output is capable of sinking up to 16mA, so an external pull-up resistance can be added to increase load driving capability and reduce output rise time.

On a 5 V supply, an external pull-up resistance no lower than 323 Ω may be used to stay within the 16 mA limit. In active low input mode, each PTM-1 input has a 10 k Ω pull-up resistor to 5 V which will act in parallel with the detector's internal resistor to draw approximately 1 mA when the detector is active. This is well within the detector's current limit, but is still more than adequate in terms of signal rise time, so no additional resistors are required in a PTM-1 installation.

IR Emitter

The IR emitter (Osram SFH409) is a miniature light emitting diode that produces an invisible beam of infra-red light from its domed lens at a wavelength which matches the peak sensitivity of the detector. The body of the emitter is 3 mm in diameter and circular in cross-section, allowing it to be mounted by push-fitting into a drilled hole through a suitable flat panel.

To produce an infra-red output, the emitter must be supplied with a current at an appropriate level and in the correct direction through it. The leads of the emitter are identified as below, noting that the cathode is the shorter of the two leads and is also the one nearest the flat on the side of the package base:

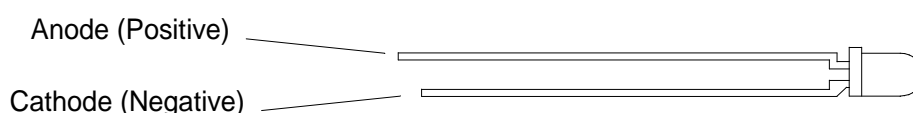

The level of current required in the emitter depends on the separation between the emitter and the detector that it will illuminate. For typical music book, roll scanning or key sensing applications with emitter-to-detector separation distances of around 5 to 10 mm, an emitter current of 5 mA will be sufficient. The maximum current that the emitter should be operated at is 50 mA, but this is likely to be far greater than necessary for music applications. The current must always flow from anode (positive) to cathode (negative). Reverse connection can cause permanent damage.

At 5 mA forward current, the voltage drop across a single IR emitter is approximately 1.1 V and a series current limiting resistor will be needed to set this current when driving it from a constant voltage power supply. For a single emitter with its own series resistor, the resistor value can be calculated as follows:

$$\text{Series Resistance } (\Omega) = (\text{Supply Voltage} - 1.1 \text{ Volts}) / 0.005$$

For example, if using a 12 V power supply, a series resistance of 2180 Ω would be appropriate (2.2 k Ω is the nearest standard value). The series resistance can be connected on either the anode or cathode side as convenient.

Since most scanner applications will require more than one pair of emitters and detectors, it is often possible to connect more than one emitter in series and share one series resistor between them. Not only does this reduce the total number of resistors required, it produces less electrical losses than using a separate series resistor for each emitter. This is particularly so when the power supply voltage being used to power the emitters is more than a few volts. The following table provides recommended standard resistor values in Ohms (0.25 W or greater power rating) for one to ten emitters in series for a range of common power supply voltages.

Recommended Series Current Limiting Resistor Values (Ω)										
Power Supply Voltage	Number of IR Emitters in Series									
	1	2	3	4	5	6	7	8	9	10
5	750	560	330	120	-	-	-	-	-	-
6	1k0	750	560	330	100	-	-	-	-	-
9	1k6	1k5	1k1	1k0	680	470	270	-	-	-
12	2k2	2k0	1k8	1k5	1k2	1k1	820	680	430	200
15	2k7	2k7	2k4	2k2	2k0	1k8	1k5	1k2	1k0	820

Application Example

The circuit diagram below shows an example of four IR-Pairs being used in a music scanning arrangement as inputs to a PTM-1. For larger installations, the same arrangement can be repeated as necessary to build up the required number of pairs.

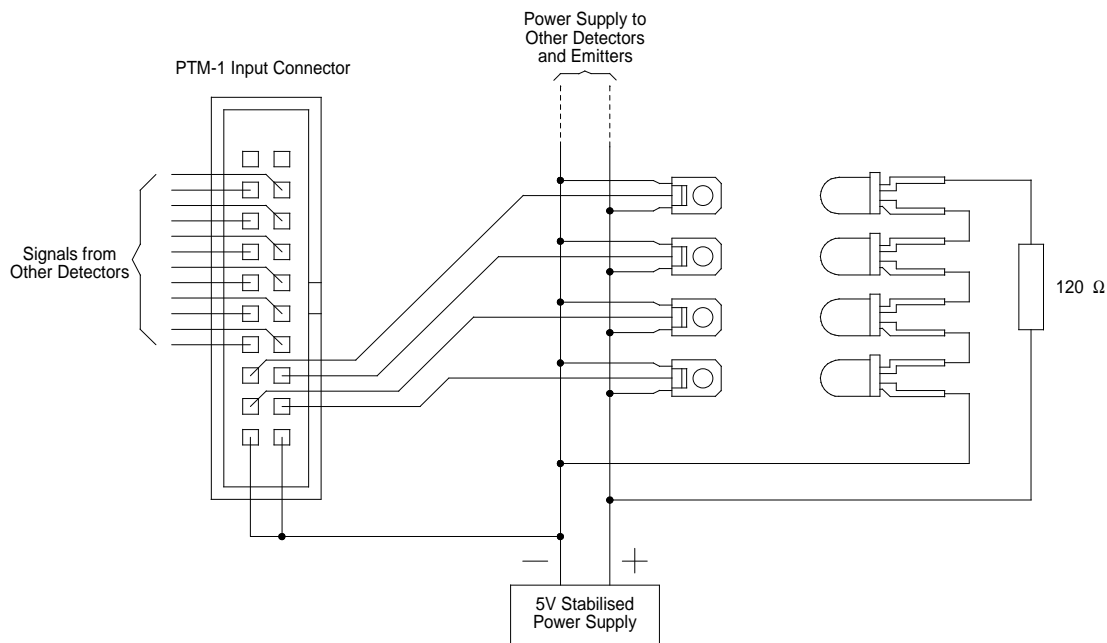

Note in the circuit shown above, both the emitters and detectors are powered from the same 5 V supply. Although longer strings of series-connected emitters can be powered from higher voltages, the detectors must always be powered at 5 V. Where two power supplies are used (one for the emitters, one for the detectors), only the 5 volt supply for the detectors needs to be connected to the PTM-1 (via pins 1 and 2 of an input connector). The power supply for the emitters can be electrically separate if required.

Document Version 1, September 2015

For the latest product information and support, please visit www.j-omega.co.uk